

**FAG**



## **Axial spherical roller bearings E1**

Higher cost-effectiveness and operational security with X-life

**SCHAEFFLER GROUP**  
INDUSTRIAL



# Welcome to the Future! Unmatched Engineering Excellence. INA and FAG



## Partner Power

X-life – this is the premium grade from INA and FAG, offering you new opportunities for success. Benefit from the combined expertise of two brands with a worldwide reputation – in every area of application covering automotive, machine building and precision engineering.

In the Schaeffler Group, INA and FAG have brought together their strengths to give a new dimension in quality:

**X-life.**  
**Higher cost-effectiveness.**  
**Higher operational security.**

### What X-life offers:

X-life offers excellent product quality that far exceeds previous standards.

Furthermore, X-life optimises all the parameters that are decisive for a problem-free production cycle. This includes correct fitting and dismantling, maintenance intervals matched to the specific application and the selection of lubricants matched to operating conditions.

A further convincing advantage of X-life is product characteristics that fulfil your specific requirements and offer additional benefits: for example, particularly low-noise, maintenance-friendly or high load capacity system solutions.

### Your X-life advantages at a glance:

- product characteristics far above the norm
- lasting quality assurance and control
- extremely high reliability
- even greater security in planning and systems
- optimum availability
- smooth-running work processes
- reduced energy consumption
- the maximum possible cost-effectiveness
- the maximum possible level of service and support

**Welcome to the Future!**  
**Unmatched Engineering Excellence.**  
**INA and FAG**

**FAG**

**SCHAEFFLER GROUP**  
INDUSTRIAL

# Contents

<b>Axial spherical roller bearings E1</b>	
Higher cost-effectiveness and operational security	2
Advantages of X-life quality	2
The range of axial spherical roller bearings E1	3
<b>Features of axial spherical roller bearings E1</b>	<b>4</b>
Dimensions	4
Compensation of angular misalignments	4
Lubrication	4
Operating temperature	4
Cages	4
<b>Design and safety guidelines</b>	<b>5</b>
Equivalent dynamic bearing load	5
Equivalent static bearing load	5
Static load safety factor	5
Minimum axial load	5
Speeds	5
Design of adjacent parts	6
Accuracy	6
<b>Application areas of axial spherical roller bearings E1</b>	<b>7</b>
<b>Products for mounting, maintenance and monitoring</b>	<b>7</b>
<b>Dimensions and performance data of axial spherical roller bearings E1</b>	<b>8</b>

# Axial spherical roller bearings E1

Higher cost-effectiveness and operational security · Advantages of X-life quality

## Higher cost-effectiveness and operational security

FAG axial spherical roller bearings in the E version have proved highly effective where high axial loads are present and there is a need to compensate for shaft deflections and/or misalignment of bearing seats.

Since the introduction of the E version axial spherical roller bearings, new knowledge has been gained on bearing kinematics, production processes have been refined and materials with higher performance have been developed.

This knowledge and potential has been utilised in the development of the new E1 version of FAG axial spherical roller bearings. Due to the even higher axial load carrying capacity and the lower bearing temperature as well as the improved security against wear, it has been possible to further improve the operational security and cost-effectiveness. The E1 version will progressively supersede the commonly used axial spherical roller bearings of version E.

**Bearings in X-life quality (see dimension tables) will have a significantly better price/performance ratio.**

## Advantages of X-life quality

- **Higher performance bearing arrangements: more than double the rating life** due to basic dynamic load ratings that are up to 30 % higher than before (see diagram), **higher static load safety factor** due to basic static load ratings nearly 10 % higher, **reduced wear** due to improved surface quality and optimum lubricant film formation, **higher speed capability** due to reduced friction and operating temperature as well as special cage designs.

This is all made possible by longer rolling elements, optimised contact geometry and bearing kinematics, improved surfaces of

the rolling contact partners for an optimised lubricant film, cages with better guidance of rollers and lubricant as well as closer dimensional and running tolerances.

The user can apply the higher performance capacity in different ways:

Under the same operating conditions, the life of the bearing arrangement is significantly longer. Alternatively, the existing life can be achieved even with a considerable increase in load.

In new designs, the performance of the larger bearings previously used can now be achieved using smaller bearings.

Through downsizing (smaller design envelope, reduced mass, lower lubricant requirement, higher speeds), more economical bearing arrangements can be realised. Due to the increased operational security, machine availability is increased.

- **Lower operating costs:** Improved bearing kinematics and higher quality of the rollers and raceways give reduced friction and lower bearing temperatures. As a result, less strain is placed on the lubricant. The maintenance intervals are longer and the maintenance costs are lower.

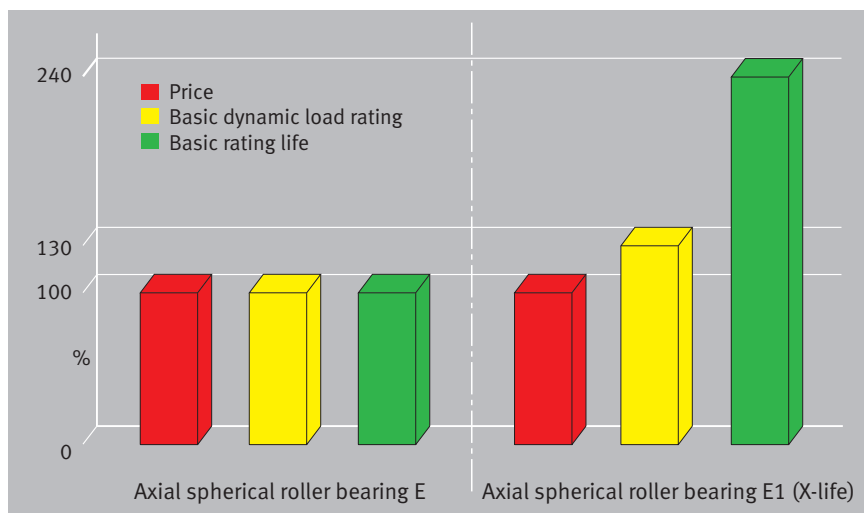

# Axial spherical roller bearings E1

Range

## The range of FAG axial spherical roller bearings E1

The transition to the new design of axial spherical roller bearings will begin with the bearings of heavy series 294..-E1. These bearings are predominantly used in response to very high requirements for load carrying capacity. Smaller bearings of series 294..-E1, as well as smaller bearings of the medium heavy series 293..-E1, have sheet steel cages. The larger bearings of these two series have a solid brass cage as standard. Numerous bearings of the series 293..-E1 and 294..-E1 are of X-life quality. These bearings are indicated in the dimension tables.

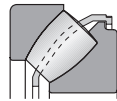

Sheet steel cage

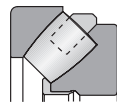

Solid brass cage

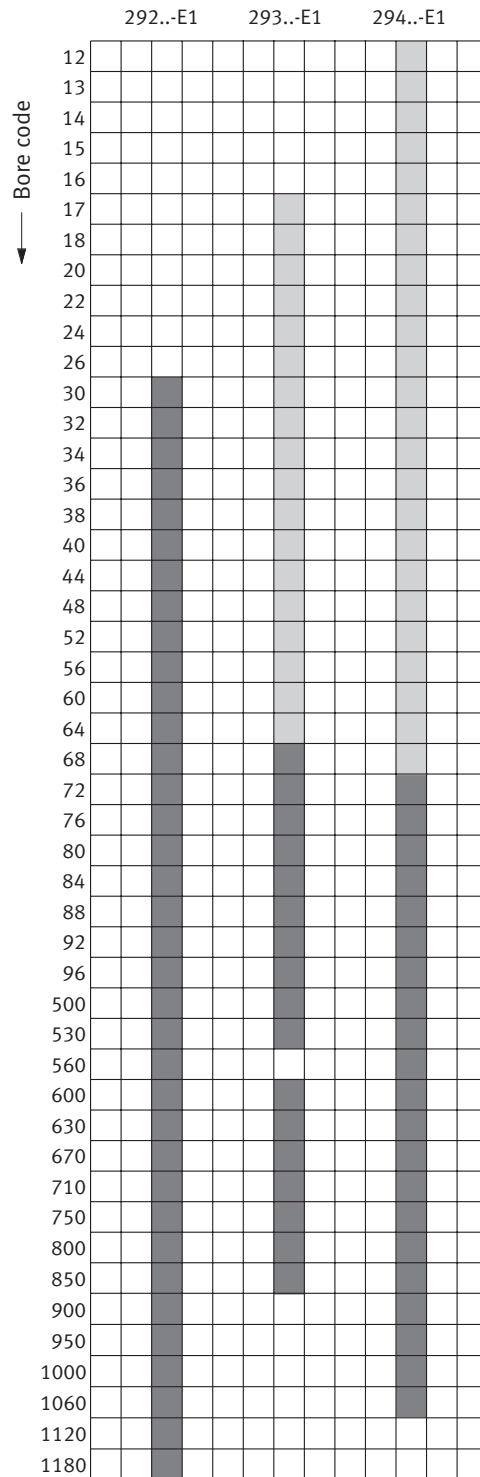

Available FAG axial spherical roller bearings E1:  
The sizes with dark colouring have a solid brass cage as standard, the others have a sheet steel cage.

# Features of axial spherical roller bearings E1

Dimensions · Compensation of angular misalignments · Lubrication · Operating temperature · Cages

## Features of axial spherical roller bearings E1

The FAG axial spherical roller bearing E1 is a bearing for the heaviest loads. The single row bearing comprises one shaft locating and one housing washer, together with asymmetrical spherical rollers in a cage. The cage holds the roller and cage assembly and the shaft locating washer together. The bearings can be dismantled. The bearing components can be mounted separately.

Axial spherical roller bearings can support very high axial loads and allow relatively high speeds. Since the raceways are inclined relative to the bearing axis, the bearings can also support radial loads. Radial load carrying capacity: see page 5.

FAG axial spherical roller bearings E1 have a very large number of rollers with a large diameter and long length. Due to the narrow osculation between the rollers and raceways, uniform stress distribution and high load carrying capacity is achieved.

### Dimensions

The main dimensions of FAG axial spherical roller bearings E1 correspond to DIN 728 and ISO 104. Due to the new internal design (higher shaft and housing locating washer, some diameters changed), the bearings are only conditionally interchangeable with FAG axial spherical roller bearings E. This must be taken into consideration before mounting, see Design of adjacent parts, page 6.

### Compensation of angular misalignments

Axial spherical roller bearings can be swivelled about their central position by a few degrees, see table Permissible skewing. In this way, they can compensate misalignment, shaft deflection and housing deformation. The adjustment angles in the table are permissible under the following conditions:

- $P$  or  $P_0 \leq 0,05 \cdot C_{0a}$
  - constant angular deviation (static angular misalignment)
  - rotating shaft locating washer.
- The lower values are valid for large bearings.

#### Permissible skewing <sup>1)</sup>

Series	Permissible skewing
292..-E1	1° to 1,5°
293..-E1	1,5° to 2,5°
294..-E1	2° to 3°

<sup>1)</sup> If the housing locating washer rotates or the shaft locating washer undergoes tumbling motion, the angular adjustment facility is smaller.

### Lubrication

Axial spherical roller bearings are not sealed and not greased. They are generally lubricated using oil.

The improved kinematics, reduced friction and better lubricant guidance give lower operating temperatures and in many cases allow lubrication using grease containing EP additives. Adequate supply to the contact points between the rollers and

guidance rib is best achieved if the bearings are completely filled with grease.

### Operating temperature

Axial spherical roller bearings E1 can be used at operating temperatures from -30 °C to +200 °C, restricted by the lubricant.

### Cages

The standard cage for smaller axial spherical roller bearings E1 (with the exception of series 292..-E1) is a sheet steel cage, in which case there is no suffix. This window cage is characterised by a robust design and low wear. The guidance of rollers and lubricant is significantly better compared to the existing cage. This gives quieter and cooler running.

A solid brass cage (suffix MB) is standard in bearings of series 292..-E1 and in larger bearings of series 293..-E1 and 294..-E1. This radially rigid brass cage is characterised by particularly good emergency running and low noise generation.

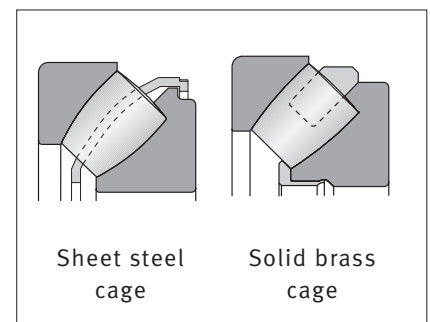

The allocation of standard cage variants to the bearing sizes is shown in the overview on page 3.

# Design and safety guidelines

Equivalent dynamic load · Equivalent static load · Static load safety factor · Minimum axial load · Speeds

## Design and safety guidelines

### Equivalent dynamic bearing load

$$P = F_a + 1,2 \cdot F_r$$

- P kN  
Equivalent dynamic bearing load for combined load
- F<sub>a</sub> kN  
Axial dynamic bearing load
- F<sub>r</sub> kN  
Radial dynamic bearing load

The radial bearing load must not exceed 55% of the axial load:  
 $F_r \leq 0,55 \cdot F_a$ .

### Equivalent static bearing load

$$P_0 = F_{0a} + 2,7 \cdot F_{0r}$$

- P<sub>0</sub> kN  
Equivalent static bearing load for combined load
- F<sub>0a</sub> kN  
Axial static bearing load
- F<sub>0r</sub> kN  
Radial static bearing load

The radial bearing load must not exceed 55% of the axial load:  
 $F_{0r} \leq 0,55 \cdot F_{0a}$ .

### Static load safety factor

For the static load safety factor, the following values must be observed:

#### Static load safety factor S<sub>0</sub>

Static load safety factor S <sub>0</sub>	Preconditions
S <sub>0</sub> ≥ 8	Axial support by the abutting shoulders in accordance with the bearing tables (d <sub>a</sub> and D <sub>a</sub> )
S <sub>0</sub> ≥ 6	Full axial support of the housing and shaft locating washers on the entire abutment surface (D <sub>1</sub> and d <sub>1</sub> from dimension tables)
S <sub>0</sub> ≥ 4	Full axial support (D <sub>1</sub> and d <sub>1</sub> from dimension tables) at the same time as good radial support of the housing locating washer (housing tolerance K7)

### Minimum axial load

The minimum axial load F<sub>a min</sub> according to the formula must be applied.

$$F_{a \min} = 0,0005 \cdot C_{0a} + k_a \left( \frac{C_{0a} \cdot n}{10^8} \right)^2$$

- F<sub>a min</sub> N  
Minimum axial load
- k<sub>a</sub> –  
Factor for determining the minimum load, see table (right hand column)

- C<sub>0a</sub> N  
Basic static load rating (note dimensions)
- n min<sup>-1</sup>  
Speed

#### Factor k<sub>a</sub>

Series	Factor k <sub>a</sub>
292..-E1	0,6
293..-E1	0,9
294..-E1	0,7

### Speeds

Suitability for high speeds is normally dependent on whether a bearing has low friction and therefore generates little heat. In the development of FAG axial spherical roller bearings E1, particular importance was therefore attached to favourable friction behaviour. The surfaces are designed such that a stable lubricant film is quickly formed. Both the sheet steel cage and the solid brass cage are optimised for favourable lubricant guidance.

For FAG axial spherical roller bearings E1, the limiting speeds n<sub>G</sub> are approx. 50% higher than for bearings of version E. This is due to the higher strength of the cages and the improved guidance of rollers and lubricant. The improved running accuracy also plays a role in this respect. The n<sub>G</sub> values in the dimension tables are valid for oil lubrication and must not be exceeded. The reference speeds n<sub>B</sub> were calculated in accordance with ISO 15312.

# Design and safety guidelines

Design of adjacent parts · Accuracy

## Design of adjacent parts

The abutting shoulders should be rigid, flat and perpendicular to the axis of rotation.

A recess of diameter  $D_{b\ min}$  according to the dimension table must be provided above the housing locating washer in the housing bore.

Otherwise, the rollers will graze the housing when the shaft traverses. Due to the new internal design (see the diagram on the right), careful attention must be paid to the mounting dimensions.

In axial spherical roller bearings E1 with a sheet steel cage, attention must be paid to the design of the spacer sleeve on the shaft locating washer (dimensions  $d_b$ ,  $d_{b1}$ ).

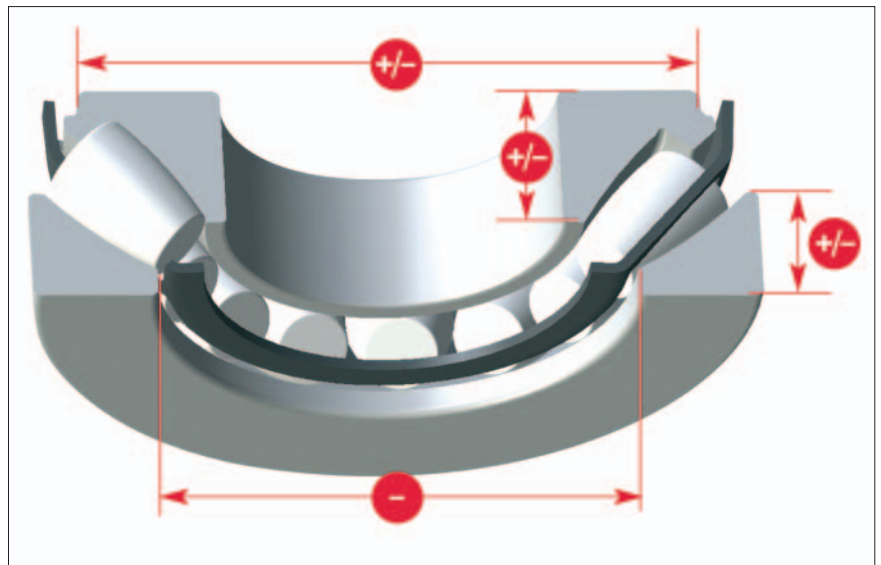

## Tolerances for shaft and housing

The runout tolerances of the abutting shoulders should be to IT5 or better. The tolerances for the shaft and locating bore must be applied in accordance with the table.

## Accuracy

The dimensional tolerances of axial spherical roller bearings E1 correspond to tolerance class PN to DIN 620-3, but the section height tolerance is restricted by up to 70 % compared with the standard.

### Shaft and housing tolerances

Adjacent part	Load type	Operating conditions	Tolerance
Shaft	Combined load	Point load on shaft locating washer	j6
		Circumferential load on shaft locating washer, shaft diameter up to 200 mm	j6 (k6)
		Circumferential load on shaft locating washer, shaft diameter over 200 mm	k6 (m6)
Housing	Axial load	Normal loads	E8
		High loads	G7
	Combined load	point load for housing locating washer	H7
		Circumferential load on housing locating washer	K7



## Application areas · Products for mounting, maintenance and monitoring

### Application areas of axial spherical roller bearings E1

In gearboxes, calenders, ships' propulsion systems and steering gear, hoists, construction machinery and rolling mills, wherever very high load carrying capacity and long life are required, under very demanding ambient conditions – FAG axial spherical roller bearings E1 are the right choice.

Depending on the application, differing requirements can be placed on axial spherical roller bearings.

In rudder bearings performing only slight swivel movements, for example, high static load carrying capacity is the important factor. FAG axial spherical roller bearings E1 with grease lubrication can be combined with FAG housings to form complete units. These rudder carrier bearings RS are optimally matched to steering gear without shear force.

In ships' thrust block bearings – units with plummer block or flanged housings – axial spherical roller bearings are used to support the high axial forces and are lubricated using oil due to the very high speeds.

Very high loads, and in many cases shocks too, are securely supported by these bearings in mining, processing equipment and in construction machinery.

In order to construct cost-effective ships' transmissions, axial spherical roller bearings are often used due to their high axial load carrying capacity and angular adjustment capability.

### FAG products for mounting, maintenance and monitoring

In order to ensure that the high performance capability of FAG axial spherical roller bearings E1 can be exploited to the full, special attention must be paid to their mounting and dismounting, lubrication, sealing and maintenance.

In situations where a production stoppage can incur high costs, monitoring of rolling bearings is advisable and cost-effective.

The methods used for the mounting and dismounting of bearings are described in detail in the publication WL 80 100 "Mounting of rolling bearings".

An overview of suitable FAG tools and measuring devices as well as diagnostic equipment is given in the publication WL 80 250 "FAG Equipment and Services for the Mounting and Maintenance of Rolling Bearings". This shows, for example, induction heating devices, extraction devices, hydraulic nuts, hand pump sets, feeler gauges, temperature measuring devices, equipment for vibration diagnosis and lubrication systems.



FAG induction heating device

# Axial spherical roller bearings E1

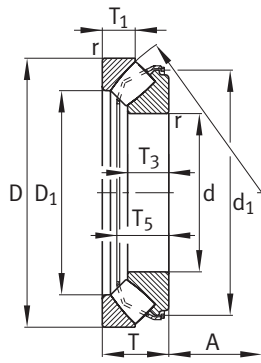

293...-E1, 294...-E1

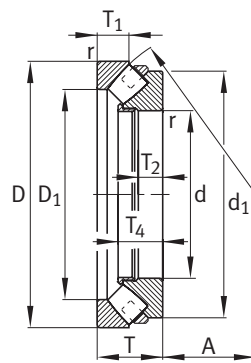

292...-E1-MB

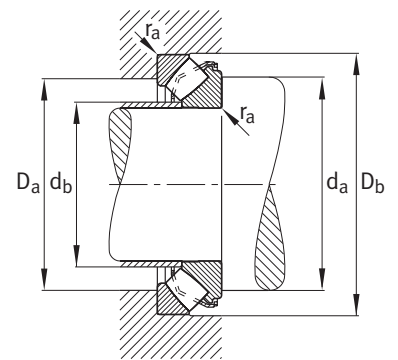

Mounting dimensions  
293...-E1, 294...-E1

## Dimension table · Dimensions in mm

Designation	X-life	Mass m ≈ kg	Dimensions											
			d	D	T	D <sub>1</sub>	d <sub>1</sub>	r	T <sub>1</sub>	T <sub>2</sub>	T <sub>3</sub>	T <sub>4</sub>	T <sub>5</sub>	A
														min.
29412-E1	XL	2,5	60	130	42	85,5	116,5	1,5	21	–	27	–	36,7	38
29413-E1	XL	3,1	65	140	45	91,5	125,2	2	22	–	29,5	–	39,8	42
29414-E1	XL	3,8	70	150	48	99	133,8	2	23,8	–	31	–	41	44,8
29415-E1	XL	4,6	75	160	51	105,5	142,3	2	24,5	–	33,5	–	45,7	47
29416-E1	XL	5,5	80	170	54	112,5	150,9	2,1	26,5	–	35	–	48,1	50
29317-E1	XL	2,7	85	150	39	109,5	138,5	1,5	20	–	24,5	–	33,8	50
29417-E1	XL	6,5	85	180	58	121	159,3	2,1	28	–	37	–	51,1	54
29318-E1	XL	2,8	90	155	39	115	142,3	1,5	19,5	–	24,5	–	34,5	52
29418-E1	XL	7,5	90	190	60	127,5	167,7	2,1	28,5	–	39	–	54	56
29320-E1	XL	3,6	100	170	42	127,5	156	1,5	20,5	–	26,2	–	36,3	58
29420-E1	XL	10,1	100	210	67	141,5	184,5	3	32	–	43	–	57,3	62
29322-E1	XL	5,2	110	190	48	140	175,6	2	24,8	–	30,3	–	41,7	64
29422-E1	XL	12,8	110	230	73	155,5	201,9	3	34,7	–	47	–	64,7	69
29324-E1	XL	7,2	120	210	54	154	192,6	2,1	27	–	34	–	48,2	70
29424-E1	XL	15,9	120	250	78	171	218,4	4	36,5	–	50,5	–	70,3	74
29326-E1	XL	8,8	130	225	58	165,5	207,9	2,1	30,1	–	36,7	–	50,6	76
29426-E1	XL	21	130	270	85	184,5	240	4	40,9	–	54	–	76	81
29328-E1	XL	10,3	140	240	60	177	220,6	2,1	30	–	38,5	–	54	82
29428-E1	XL	22,1	140	280	85	194,5	251,1	4	41	–	54	–	75,6	86
29230-E1-MB	–	4,4	150	215	39	176	200	1,5	20,5	14	25	37	–	82
29330-E1	XL	10,5	150	250	60	190	228,4	2,1	28	–	38	–	54,9	87
29430-E1	XL	27,2	150	300	90	207,5	267,4	4	43,4	–	58	–	80,8	92
29232-E1-MB	–	4,6	160	225	39	188	210	1,5	20	14	25	37	–	87
29332-E1	XL	14	160	270	67	203	248	3	33	–	42	–	60	92
29432-E1	XL	32,1	160	320	95	223,5	283,5	5	45,5	–	60,5	–	84,3	99
29234-E1-MB	–	5,6	170	240	42	201	225	1,5	22	15	26	40	–	93
29334-E1	XL	14,2	170	280	67	215	255,7	3	30,5	–	42,2	–	61	96
29434-E1	XL	39,6	170	340	103	236	305	5	50	–	65,5	–	91,2	104
29236-E1-MB	–	6	180	250	42	208	235	1,5	22	15	26	40	–	97
29336-E1	XL	18,4	180	300	73	227	274,5	3	35,5	–	46	–	66,2	103
29436-E1	XL	47,6	180	360	109	250	315,5	5	53	–	69,5	–	96,4	110
29238-E1-MB	–	8,3	190	270	48	226	255	2	25,5	17	29	45	–	103
29338-E1	XL	22,3	190	320	78	243,5	290,1	4	36	–	49	–	71,3	110
29438-E1	XL	54,6	190	380	115	264,5	340	5	55,5	–	73	–	101	117

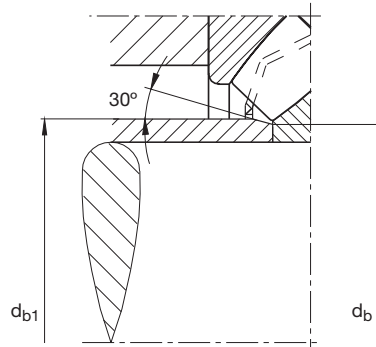
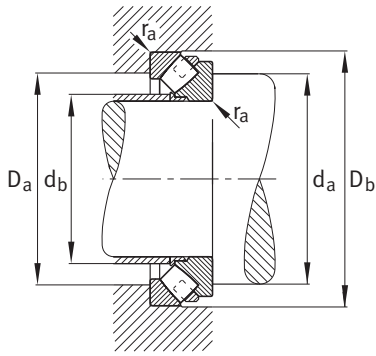

Mounting dimensions  
292...E1-MB

**Mounting dimensions**

**Basic load ratings**

**Fatigue limit load**

**Limiting speed**

**Reference speed**

$d_a$	$D_a$	$D_b$	$d_b$	$d_{b1}$	$r_a$	dyn. $C_a$	Basic load ratings stat. $C_{0a}$	Fatigue limit load $C_{ua}$	Limiting speed $n_G$	Reference speed $n_B$
min.	max.	min.	max.	max.	max.	kN	kN	kN	$\text{min}^{-1}$	$\text{min}^{-1}$
95	107	133	67	–	1,5	420	970	116	6 000	2 750
100	115	143	72	–	2	495	1 160	137	5 300	2 550
110	124	153	78,5	–	2	550	1 290	151	5 000	2 420
115	132	163	82,5	–	2	650	1 540	176	4 800	2 230
125	141	173	88	–	2	720	1 720	196	4 500	2 120
120	129	153	92	–	1,5	420	1 110	146	4 800	2 270
130	150	183	94	–	2	800	1 910	220	4 000	2 010
125	135	158	97	–	1,5	420	1 130	152	4 800	2 160
135	158	193	99,5	–	2	880	2 130	241	4 000	1 910
135	148	173	107	–	1,5	495	1 340	181	4 300	1 970
150	175	214	110,5	–	2,5	1 060	2 600	285	3 400	1 740
150	165	193	120	–	2	620	1 760	217	3 600	1 850
165	192	234	121	129	2,5	1 260	3 150	345	3 000	1 600
165	182	213	129	–	2	800	2 210	270	3 400	1 710
180	210	254	132	142	3	1 460	3 700	390	2 800	1 470
180	195	228	139	143	2	900	2 600	300	3 000	1 590
195	227	275	143	153	3	1 700	4 350	450	2 600	1 360
190	208	244	149	154	2	1 010	2 900	340	2 800	1 500
205	237	285	154	162	3	1 710	4 500	495	2 600	1 300
185	193	219	157	–	1,5	425	1 720	204	3 000	1 560
195	220	254	159	163	2	1 020	2 900	360	2 600	1 410
220	253	306	164	175	3	2 000	5 300	560	2 200	1 190
195	204	229	168	–	1,5	420	1 720	214	3 000	1 470
215	236	274	170	176	2,5	1 220	3 550	420	2 600	1 330
235	271	326	176	189	4	2 240	6 000	630	2 200	1 090
205	218	244	180	–	1,5	470	1 940	238	2 800	1 420
220	247	284	180	188	2,5	1 220	3 500	435	2 400	1 260
250	288	346	186	199	4	2 550	6 900	700	2 000	1 030
215	226	254	192	–	1,5	470	2 050	250	2 600	1 380
235	263	304	190	195	2,5	1 460	4 300	495	2 200	1 170
265	305	366	197	210	4	2 850	7 700	770	1 800	940
230	243	274	203	–	2	600	2 500	295	2 400	1 330
250	281	325	201	211	3	1 680	4 850	580	2 200	1 090
280	322	386	209	223	4	3 100	8 600	870	1 800	910

# Axial spherical roller bearings E1

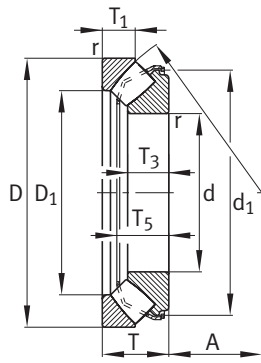

293...-E1, 294...-E1

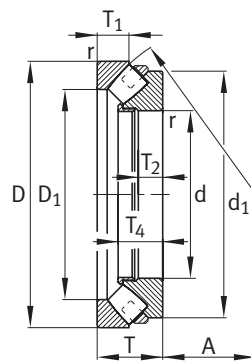

292...-E1-MB, 293...-E1-MB,  
294...-E1-MB

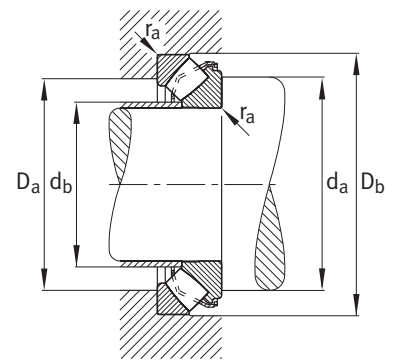

Mounting dimensions  
293...-E1, 294...-E1

## Dimension table · Dimensions in mm

Designation	X-life	Mass m ≈ kg	Dimensions											
			d	D	T	D <sub>1</sub>	d <sub>1</sub>	r	T <sub>1</sub>	T <sub>2</sub>	T <sub>3</sub>	T <sub>4</sub>	T <sub>5</sub>	A
														min.
29240-E1-MB	-	8,9	200	280	48	232,5	265	2	24	17	30	45	-	108
29340-E1	XL	27,3	200	340	85	257	308,8	4	40	-	53,5	-	76,7	116
29440-E1	XL	63,7	200	400	122	277,5	360	5	59,4	-	77	-	107,1	122
29244-E1-MB	-	9,6	220	300	48	251,5	285	2	24,5	17	30	45	-	117
29344-E1	XL	30,6	220	360	85	275,5	331,8	4	41	-	55	-	77,7	125
29444-E1	XL	69	220	420	122	300	379,8	6	58,5	-	77	-	107,4	132
29248-E1-MB	-	16,6	240	340	60	283	320	2,1	30	22	37	57	-	130
29348-E1	XL	32,8	240	380	85	295,5	350,6	4	40,5	-	54	-	77,8	135
29448-E1	XL	74,1	240	440	122	322	400	6	59	-	76	-	107,1	142
29252-E1-MB	-	17,8	260	360	60	302	340	2,1	30	22	38	57	-	139
29352-E1	XL	45,8	260	420	95	324	387,7	5	46	-	61	-	86,6	148
29452-E1	XL	96,6	260	480	132	346	435	6	63	-	86	-	119	154
29256-E1-MB	-	19	280	380	60	323	360	2,1	30	22	38	57	-	150
29356-E1	XL	49,1	280	440	95	343	406,5	5	45,5	-	62	-	86,7	158
29456-E1	XL	126	280	520	145	372	473,1	6	70	-	95	-	129,9	166
29260-E1-MB	-	30,1	300	420	73	353	395	3	38	26	44	69	-	162
29360-E1	XL	65,1	300	480	109	372	439,6	5	51	-	70	-	98,9	168
29460-E1	XL	130	300	540	145	392	490	6	70,5	-	95	-	130,3	175
29264-E1-MB	-	31,7	320	440	73	372	415	3	38	26	44,5	69	-	172
29364-E1	XL	72,4	320	500	109	391	460	5	53	-	68	-	97,8	180
29464-E1	XL	163	320	580	155	422	534,4	7,5	74,5	-	102	-	139,4	191
29268-E1-MB	-	33,3	340	460	73	395	435	3	37	26	45	69	-	183
29368-E1-MB	XL	101	340	540	122	428	500	5	59,5	44	75	117	-	192
29468-E1	XL	208	340	620	170	445	564,9	7,5	84	-	112	-	151,4	201
29272-E1-MB	-	48,5	360	500	85	423	470	4	44	31	51	81	-	194,5
29372-E1-MB	XL	105	360	560	122	448	520	5	59,5	44	75	117	-	202
29472-E1-MB	XL	230	360	640	170	474	585	7,5	83,5	63	110	164	-	210
29276-E1-MB	-	50,7	380	520	85	441	490	4	42	31	51,5	81	-	202
29376-E1-MB	XL	136	380	600	132	477	555	6	63,5	48	83	127	-	216
29476-E1-MB	-	260	380	670	175	494	615	7,5	87,5	67	115	168	-	222
29280-E1-MB	-	53,2	400	540	85	460	510	4	42	31	53,5	81	-	212
29380-E1-MB	XL	142	400	620	132	494	575	6	64	48	83	127	-	225
29480-E1-MB	-	308	400	710	185	525	650	7,5	89,5	69	120	178	-	234
29284-E1-MB	-	70,7	420	580	95	489	545	5	46	34	58,5	91	-	225
29384-E1-MB	-	163	420	650	140	520	600	6	67,5	50	85	135	-	235
29484-E1-MB	-	320	420	730	185	545	670	7,5	90,5	70	124	178	-	244

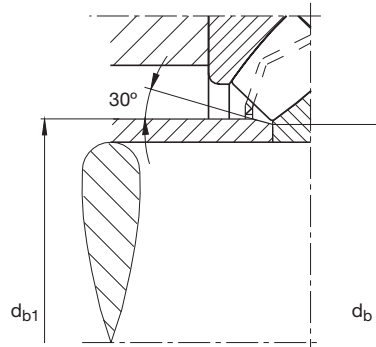
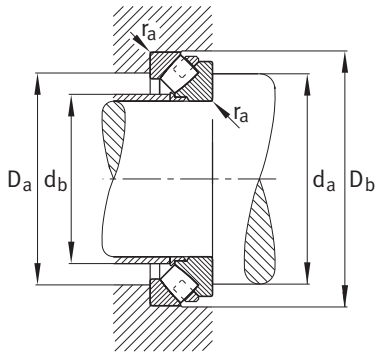

Mounting dimensions 292..-E1-MB,  
293..-E1-MB, 294..-E1-MB

**Mounting dimensions**

**Basic load ratings**

**Fatigue limit load**

**Limiting speed**

**Reference speed**

$d_a$	$D_a$	$D_b$	$d_b$	$d_{b1}$	$r_a$	dyn. $C_a$	Basic load ratings stat. $C_{0a}$	Fatigue limit load $C_{ua}$	Limiting speed $n_G$	Reference speed $n_B$
min.	max.	min.	max.	max.	max.	kN	kN	kN	$\text{min}^{-1}$	$\text{min}^{-1}$
240	258	284	209	–	2	650	2 650	315	2 400	1 290
265	298	348	213	224	3	1 900	5 600	640	2 000	1 030
295	338	406	220	234	4	3 400	9 500	940	1 700	860
260	277	304	232	–	2	640	2 900	340	2 200	1 180
285	316	368	231	240	3	1 990	6 200	700	1 800	950
315	360	428	241	254	5	3 500	10 000	1 020	1 500	800
290	311	344	250	–	2	1 010	4 150	465	1 800	1 070
305	337	390	252	259	3	2 040	6 500	740	1 700	880
335	381	448	261	276	5	3 600	10 500	1 080	1 500	750
310	331	365	271	–	2	1 040	4 550	495	1 800	980
340	372	430	275	286	4	2 550	8 200	890	1 500	790
365	419	488	280	296	5	4 400	13 200	1 300	1 300	660
330	351	385	293	–	2	1 020	4 700	520	1 700	910
355	394	450	293	305	4	2 650	8 800	960	1 400	740
395	446	530	302	320	5	5 200	15 800	1 500	1 300	610
360	386	426	315	–	2,5	1 400	6 200	650	1 500	850
385	429	490	318	329	4	3 200	10 500	1 130	1 300	680
420	471	550	324	340	5	5 200	16 200	1 540	1 200	580
380	406	450	336	–	2,5	1 410	6 500	680	1 400	800
405	449	510	333	347	4	3 350	11 000	1 180	1 300	640
445	507	590	346	367	6	6 000	19 100	1 780	1 100	530
400	427	470	356	–	2,5	1 410	6 600	710	1 300	750
440	484	550	365	–	4	3 750	12 600	1 340	1 100	610
480	541	630	364	386	6	7 200	23 100	2 080	1 100	475
430	461	510	379	–	3	1 870	8 500	870	1 200	700
455	504	572	385	–	4	3 750	13 000	1 340	1 100	580
500	560	650	388	–	6	6 800	21 900	2 050	1 000	475
445	480	530	394	–	3	2 000	9 000	930	1 200	660
485	538	612	404	–	5	4 500	15 400	1 570	1 100	540
530	587	682	413	–	6	6 100	24 200	2 180	950	450
465	500	550	414	–	3	2 040	9 600	970	1 100	630
510	557	634	429	–	5	4 550	16 300	1 670	1 000	510
555	622	722	434	–	6	6 900	26 500	2 430	900	425
495	534	590	439	–	4	2 460	11 100	1 110	1 100	610
530	585	664	449	–	5	4 250	17 400	1 680	950	485
580	643	742	457	–	6	7 000	28 500	2 550	850	400

# Axial spherical roller bearings E1

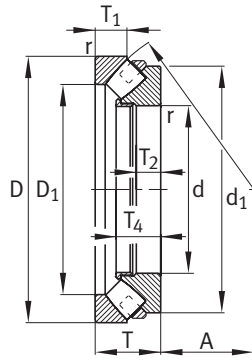

292...-E1-MB, 293...-E1-MB,  
294...-E1-MB

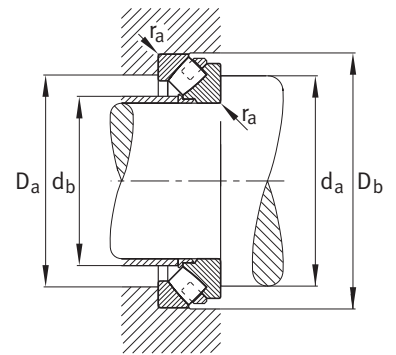

Mounting dimensions 292...-E1-MB,  
293...-E1-MB, 294...-E1-MB

## Dimension table · Dimensions in mm

Designation	Mass m ≈ kg	Dimensions										
		d	D	T	D <sub>1</sub>	d <sub>1</sub>	r	T <sub>1</sub>	T <sub>2</sub>	T <sub>3</sub>	T <sub>4</sub>	A
29288-E1-MB	77	<b>440</b>	600	95	508	570	5	49	34	61	91	235
29388-E1-MB	185	<b>440</b>	680	145	540	631,5	6	70,5	52	87	140	245
29488-E1-MB	410	<b>440</b>	780	206	577	715	9,5	101	77	134	199	257
29292-E1-MB	77,7	<b>460</b>	620	95	530	585	5	46	34	59	91	245
29392-E1-MB	207	<b>460</b>	710	150	567	660	6	72,5	54	94,5	144	257
29492-E1-MB	430	<b>460</b>	800	206	596	735	9,5	101,5	77	135	199	268
29296-E1-MB	95,6	<b>480</b>	650	103	556	620	5	55	37	62	99	259
29396-E1-MB	219	<b>480</b>	730	150	591	680	6	73,5	54	94	144	270
29496-E1-MB	531	<b>480</b>	850	224	625	780	9,5	108	88	147	216	280
292/500-E1-MB	101	<b>500</b>	670	103	574	640	5	55	37	65	99	268
293/500-E1-MB	228	<b>500</b>	750	150	611	700	6	74	54	92	144	280
294/500-E1-MB	551	<b>500</b>	870	224	648	800	9,5	110	86	147	216	290
292/530-E1-MB	118	<b>530</b>	710	109	608	675	5	57	39	64	105	285
293/530-E1-MB	274	<b>530</b>	800	160	648	745	7,5	76	58	101,5	154	295
294/530-E1-MB	653	<b>530</b>	920	236	686	845	9,5	116	89	156	228	308
292/560-E1-MB	140	<b>560</b>	750	115	644	715	5	60	41	71	111	302
294/560-E1-MB	783	<b>560</b>	980	250	727	900	12	122	99	168	241	328
292/600-E1-MB	165	<b>600</b>	800	122	688	760	5	65	44	71,5	117	321
293/600-E1-MB	392	<b>600</b>	900	180	720	840	7,5	89	65	113,5	174	335
294/600-E1-MB	889	<b>600</b>	1030	258	769	950	12	128	99	172	249	349
292/630-E1-MB	206	<b>630</b>	850	132	723	805	6	67	48	80	127	338
293/630-E1-MB	462	<b>630</b>	950	190	761	885,5	9,5	92	68	122	183	345
294/630-E1-MB	1 070	<b>630</b>	1 090	280	815	1 000	12	137	107	183	270	365
292/670-E1-MB	245	<b>670</b>	900	140	773	855	6	74	50	81	135	361
293/670-E1-MB	526	<b>670</b>	1 000	200	809	930	9,5	96	72	126	193	372
294/670-E1-MB	1 210	<b>670</b>	1 150	290	864	1 060	15	141	110	191	280	387
292/710-E1-MB	280	<b>710</b>	950	145	815	900	6	75	52	88	140	380
293/710-E1-MB	635	<b>710</b>	1 060	212	855	985	9,5	103	76	132,5	205	394
294/710-E1-MB	1 470	<b>710</b>	1 220	308	917	1 120	15	149	117	202	298	415
292/750-E1-MB	328	<b>750</b>	1 000	150	858	950	6	81	54	89	144	409
293/750-E1-MB	735	<b>750</b>	1 120	224	910	1 040	9,5	109	81	140	216	415
294/750-E1-MB	1 650	<b>750</b>	1 280	315	964	1 180	15	153	121	210	305	436

**Mounting dimensions**

<b>Mounting dimensions</b>					<b>dyn.</b>	<b>Basic load ratings</b>	<b>Fatigue limit load</b>	<b>Limiting speed</b>	<b>Reference speed</b>
$d_a$	$D_a$	$D_b$	$d_b$	$r_a$	$C_a$	$C_{0a}$	$C_{ua}$	$n_G$	$n_B$
min.	max.	min.	max.	max.	kN	kN	kN	min <sup>-1</sup>	min <sup>-1</sup>
520	554	610	458	4	2 500	12 400	1 170	1 000	570
555	614	695	473	5	4 450	18 300	1 650	900	480
610	684	794	477	8	8 300	32 500	2 900	800	380
535	575	632	479	4	2 550	12 200	1 220	1 000	550
585	638	726	491	5	5 000	21 300	2 040	850	435
630	704	815	497	8	8 400	33 500	3 000	750	365
565	603	662	507	4	2 650	13 700	1 310	950	530
605	660	746	511	5	4 950	21 400	1 920	850	425
660	744	865	516	8	10 000	39 500	3 450	700	340
585	622	682	524	4	2 750	14 700	1 380	900	500
625	683	768	534	5	5 000	22 000	1 930	800	410
685	765	886	539	8	9 900	40 000	3 500	700	330
620	661	722	561	4	3 000	15 400	1 490	850	485
660	724	818	564	6	5 800	25 500	2 260	750	380
725	810	937	570	8	10 800	44 500	3 800	630	310
655	697	762	587	4	3 450	18 100	1 680	800	445
770	860	997	602	10	12 400	51 000	4 300	600	285
700	744	814	634	4	3 650	19 400	1 810	750	420
745	815	920	634	6	7 400	34 000	2 900	630	325
820	900	1055	649	10	12 900	56 000	4 650	560	270
735	789	864	658	5	4 650	23 600	2 150	670	395
785	856	970	666	8	8 200	37 500	3 200	600	310
860	960	1 115	678	10	14 800	62 000	5 200	530	255
785	836	915	707	5	4 750	24 900	2 260	630	375
825	906	1 020	703	8	9 000	41 000	3 300	560	285
910	1 015	1 175	723	12	15 700	66 000	5 500	500	243
825	882	966	741	5	5 500	29 500	2 550	600	340
875	962	1 082	746	8	10 000	46 000	3 650	530	270
960	1 073	1 250	762	12	17 900	76 000	6 200	480	223
875	930	1 017	789	5	5 700	31 500	2 750	560	325
925	1 015	1 142	790	8	10 800	50 000	3 850	500	255
1 015	1 130	1 310	811	12	19 000	84 000	6 700	450	210

# Axial spherical roller bearings E1

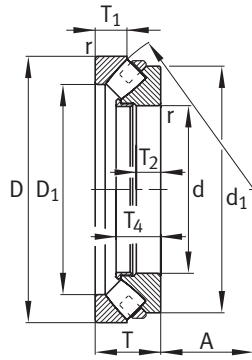

292...-E1-MB, 293...-E1-MB,  
294...-E1-MB

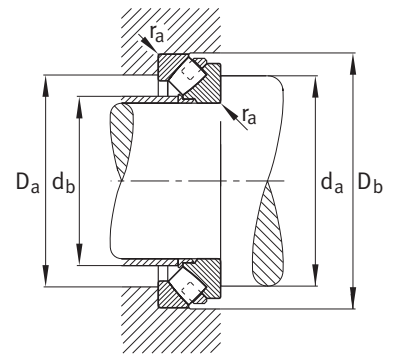

Mounting dimensions 292...-E1-MB,  
293...-E1-MB, 294...-E1-MB

## Dimension table · Dimensions in mm

Designation	Mass m ≈ kg	Dimensions											
		d	D	T	D <sub>1</sub>	d <sub>1</sub>	r	T <sub>1</sub>	T <sub>2</sub>	T <sub>3</sub>	T <sub>4</sub>	A	
							min.						
292/800-E1-MB	367	<b>800</b>	1 060	155	911	1 010	7,5	81	56	94	149	434	
293/800-E1-MB	824	<b>800</b>	1 180	230	965	1 100	9,5	111	83	145,5	222	440	
294/800-E1-MB	1 960	<b>800</b>	1 360	335	1 034	1 255	15	165	123	219	324	462	
292/850-E1-MB	415	<b>850</b>	1 120	160	967	1 070	7,5	82	58	101,5	154	455	
293/850-E1-MB	972	<b>850</b>	1 250	243	1 021	1 165	12	118	87	152	235	468	
294/850-E1-MB	2 350	<b>850</b>	1 440	354	1 077	1 325	15	172	142	239	342	490	
292/900-E1-MB	475	<b>900</b>	1 180	170	1 023	1 120	7,5	84	61	102,5	167	477	
294/900-E1-MB	2 740	<b>900</b>	1 520	372	1 137	1 405	15	186	147	251	360	518	
292/950-E1-MB	575	<b>950</b>	1 250	180	1 081	1 190	7,5	90	65	110	174	507	
294/950-E1-MB	3 170	<b>950</b>	1 600	390	1 209	1 475	15	191	153	260	377	546	
292/1000-E1-MB	688	<b>1 000</b>	1 320	190	1 139	1 255	9,5	98	68	117,5	182	540	
294/1000-E1-MB	3 570	<b>1 000</b>	1 670	402	1 250	1 540	15	200	160	277	390	581	
292/1060-E1-MB	844	<b>1 060</b>	1 400	206	1 211	1 336,3	9,5	108	74	124	199	566	
294/1060-E1-MB	4 200	<b>1 060</b>	1 770	426	1 349	1 630	15	207	192	280	412	610	
292/1120-E1-MB	887	<b>1 120</b>	1 460	206	1 272	1 395	9,5	108	74	125	199	601	
292/1180-E1-MB	930	<b>1 180</b>	1 520	206	1 331	1 455	9,5	108	74	125	199	625	



**Mounting dimensions**

$d_a$	$D_a$	$D_b$	$d_b$	$r_a$	dyn. $C_a$	Basic load ratings stat. $C_{0a}$	Fatigue limit load $C_{ua}$	Limiting speed $n_G$	Reference speed $n_B$
min.	max.	min.	max.	max.	kN	kN	kN	$\text{min}^{-1}$	$\text{min}^{-1}$
925	987	1 078	837	6	6 300	35 500	3 050	530	305
980	1 070	1 202	840	8	11 500	54 000	4 000	480	238
1 085	1 200	1 390	870	12	20 400	91 000	7 300	430	199
985	1 043	1 138	886	6	7 100	40 500	3 400	500	280
1 045	1 137	1 273	897	10	12 900	62 000	4 450	450	219
1 145	1 275	1 470	915	12	24 000	110 000	8 500	400	176
1 025	1 089	1 268	933	6	7 700	42 000	3 250	480	265
1 215	1 345	1 555	969	12	25 500	120 000	9 000	360	168
1 090	1 101	1 198	985	6	8 800	48 500	3 900	450	250
1 275	1 241	1 635	1 020	12	28 500	132 000	10 100	360	156
1 155	1 151	1 340	1 042	8	9 600	55 000	4 450	430	235
1 340	1 298	1 705	1 071	12	30 500	146 000	10 700	340	145
1 225	1 220	1 422	1 106	8	10 700	62 000	4 850	400	221
1 410	1 377	1 815	1 141	12	33 000	155 000	11 500	300	140
1 285	1 280	1 482	1 168	8	10 700	64 000	4 650	360	210
1 345	1 410	1 542	1 234	8	10 700	67 000	4 750	360	200

## Notes



**Schaeffler KG**

Georg-Schäfer-Strasse 30  
97421 Schweinfurt (Germany)  
Internet [www.fag.com](http://www.fag.com)  
E-mail [FAGdirect@de.fag.com](mailto:FAGdirect@de.fag.com)

In Germany:

Phone 0180 5003872  
Fax 0180 5003873

From other countries:

Phone +49 9721 91-0  
Fax +49 9721 91-3435

Every care has been taken to ensure the correctness of the information contained in this publication but no liability can be accepted for any errors or omissions.

We reserve the right to make technical changes.

© Schaeffler KG · 2007, April

This publication or parts thereof may not be reproduced without our permission.

WL 43 184 EA